

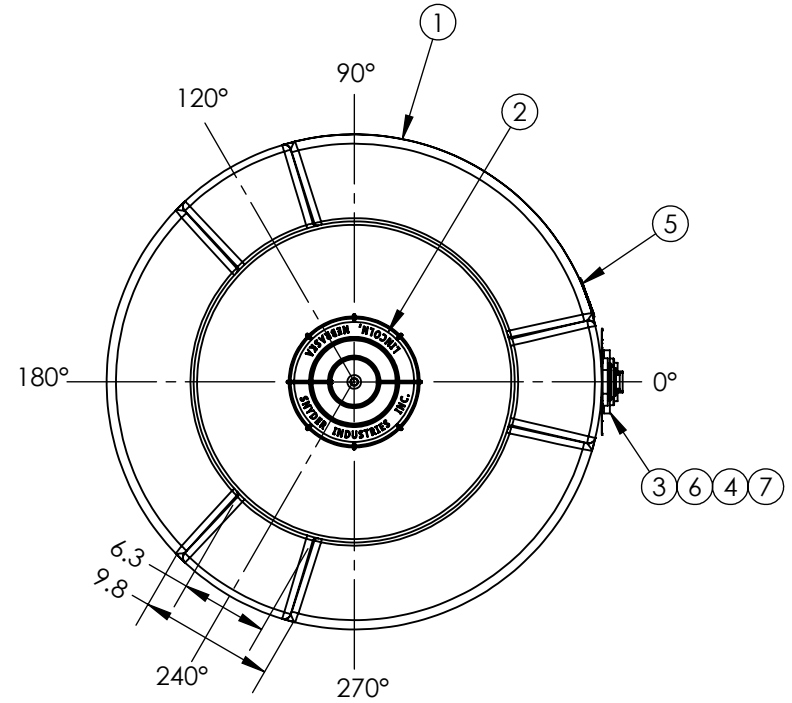

BLACK OR DARK OLIVE GREEN

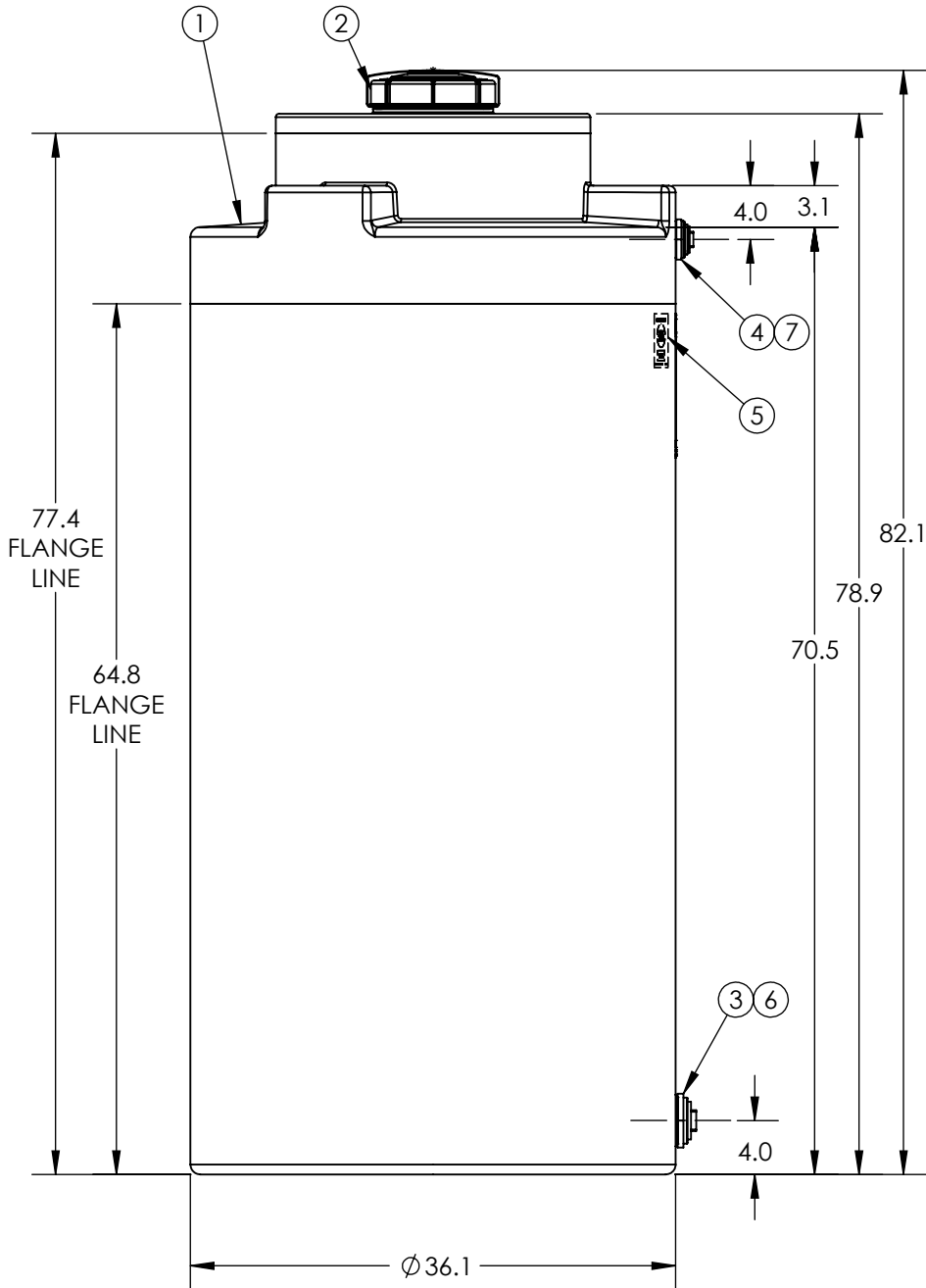

\*ALL EXTERNAL PIPING MUST BE INDEPENDENTLY SUPPORTED.  
 \*ONLY BASE FITTINGS TO BE LEFT INSTALLED AT TIME OF SHIPMENT PER SII PROCEDURE.  
 ALL DIMENSIONS ARE IN INCHES, NOMINAL, & SUBJECT TO CHANGE WITHOUT NOTICE.  
 ALL DIMENSIONS ON ROTATIONAL MOLDED PARTS ARE SUBJECT TO A ± 3% TOLERANCE.

|   |   |              |                                  |
|---|---|--------------|----------------------------------|
| 7 | 1 | 64149        | 1-1/2" NPT PLUG                  |
| 6 | 1 | 60021        | 2" NPT PLUG                      |
| 5 | 1 | 99700231     | DECAL NSF MARK - WATER TKS       |
| 4 | 1 | 63931        | FTG PP 1-1/2IN ECO-BH EPDM TXT   |
| 3 | 1 | 60405        | FTG PP 2IN BH EPDM TXT           |
| 2 | 1 | 34700088     | ASM CAP 10IN PE W/TIE            |
| 1 | 1 | 1630100W__02 | ASM TK 300VFT X 36 WATER NH NOMW |

| ITEM NO.                                                                                                                                                                                                                          | QTY. | PART NUMBER                         | DESCRIPTION                                                                                                           |          |
|-----------------------------------------------------------------------------------------------------------------------------------------------------------------------------------------------------------------------------------|------|-------------------------------------|-----------------------------------------------------------------------------------------------------------------------|----------|
| DO NOT SCALE                                                                                                                                                                                                                      |      | DRAWN BY                            | TITLE:                                                                                                                |          |
| Released                                                                                                                                                                                                                          |      | BH                                  |  <b>ASM TK 300VFT X 36 WATER</b> |          |
| © SNYDER INDUSTRIES, LLC, 2020                                                                                                                                                                                                    |      | (402) 467-5221<br>www.snydernet.com | PART NO.                                                                                                              | ENG. ID. |
| ALL DIMENSIONS, DESIGNS, AND INFORMATION ON THIS PRINT MUST BE CONSIDERED PROPRIETARY TO SNYDER INDUSTRIES, LLC, AND MAY NOT BE USED, COPIED, OR DISTRIBUTED WITHOUT WRITTEN PERMISSION OF AN OFFICER (OR HIS AGENT) OF THE FIRM. |      |                                     | 1630100W__03                                                                                                          | D006371  |
|                                                                                                                                                                                                                                   |      |                                     | REVISION                                                                                                              | B        |
|                                                                                                                                                                                                                                   |      |                                     | SHEET                                                                                                                 | 1 OF 1   |